



Dairy cows need comfortable conditions in order to maximise performance. The choice of cow cubicle is vital to optimise herd health, achieve maximum milk yield and ultimately increase farm profitability. JFC in conjunction with dairy experts have identified the conditions that contribute to maximum performance and designed the JFC Deluxe Cow Cubicle.



This innovative plastic cubicle is one of the first systems to incorporate the complete cubicle structure (including brisket board, dividers and mat) designed for maximum comfort. JFC Deluxe Cow Cubicle manufactured from medium density polyethylene plastic is strong, non-corrosive and impact resistant. The separating dividers are reinforced with high density polyurethane foam for extra stability.

Deluxe Cow Cubicle



Optimum Cow Comfort

- No restrictive neck rail so cows lie, rise and stand with ease
- Allows cows to rise in a natural manner by lunging forward
- Cows enter the cubicles without hesitation (reduced stress)
- The open cubicle structure promotes bonding
- Plastic brisket board acts as a pillow for optimum comfort
- Sufficient space & optimum positioning for increased comfort

Ultimate Safety

- Cubicle dividers designed to reduce cows getting trapped
- Plastic dividers flex sufficiently to avoid crushing and injury
- Plastic material does not rust or corrode
- Encourages natural lying and rising movement to prevent hock damage
- Generous cubicle space for pregnant cows

Health & Hygiene

- Encourages optimum positioning for defecation onto the aisle
- Designed with smooth, curved surfaces for ease of cleaning
- Optional antimicrobial mats available

IRELAND and INTERNATIONAL SALES OFFICE

JFC Manufacturing Co. Ltd.

Weir Road, Tuam,
Co Galway, Ireland

t: +353 (0)93 24066
e: info@jfc.ie

f: +353 (0) 93 24923
w: www.jfc.ie

UK SALES OFFICE

JFC Manufacturing (U.K.) Ltd.

Maes Y Clawdd Industrial Estate, Maesbury Road,
Oswestry Shropshire, SY10 8NN, UK

t: +44 (0) 1691 659226
e: info@jfcuk.com

f: +44 (0) 1691 659344
w: www.jfcuk.com



Deluxe Cow Cubicle

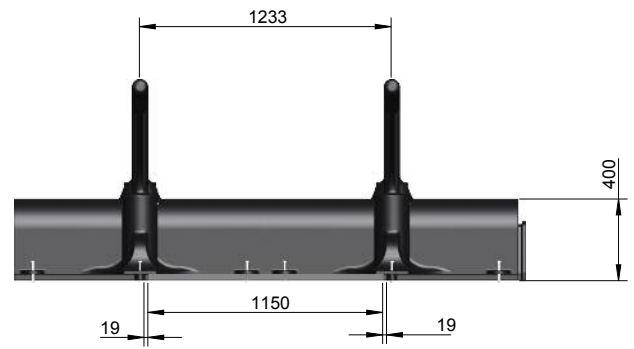
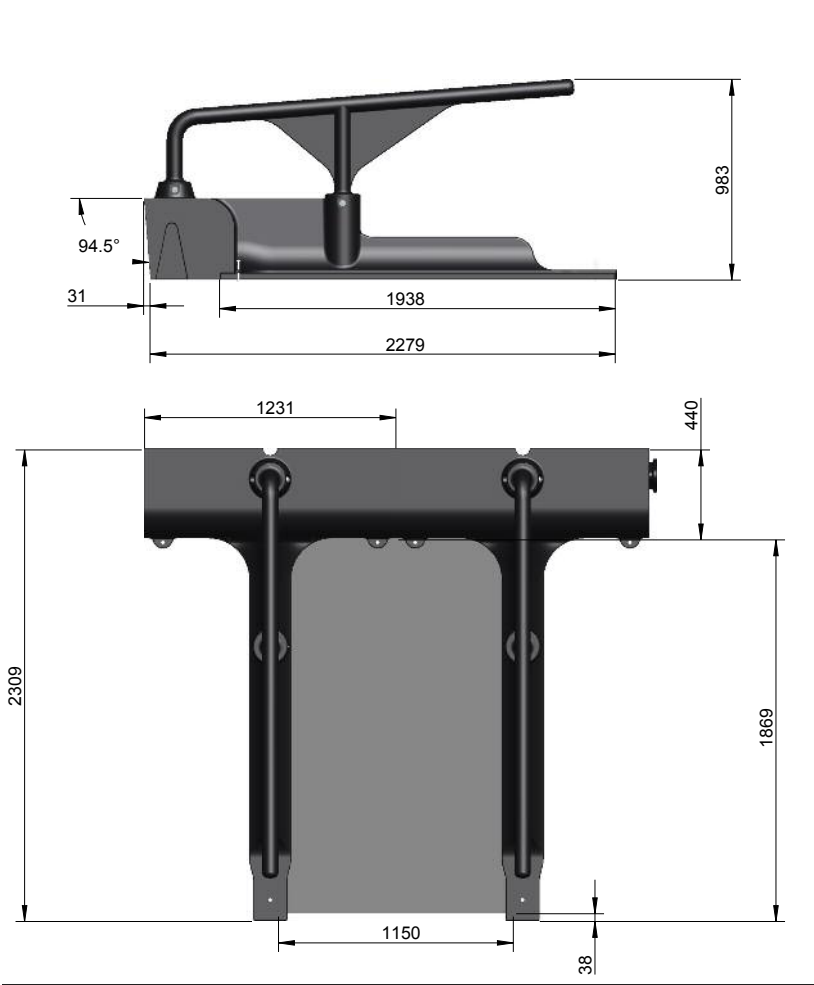

Technical Details

- Manufactured from Medium Density Polyethylene
- Easy to install on new or existing bases
- Only 3 anchor bolts required per cubicle
- No neck rail required
- Dovetail Joint Connection

Design Characteristics

- Generous radii aids the flexing of the divider reducing risk of cracking
- Cubicles interlock using dovetail method
- Flat area allows back of cubicles to be maintained using mechanical means
- Centre leg gusseted to add strength
- Mat expansion joints both sides
- Reinforcement ribs on base to improve straightness
- Dividers injected with reinforced foaming agent



	Length (mm / inches)	Width (mm / inches)	Height (mm / inches)	Length from brisket board to front of cubicle (mm / ")
Dimensions	2310 (91)	1230 (48)	980 (38)	1870 (73)

It is believed that the information marketed in this publication is correct. Products marketed by the company are however subject to continuous development and the company therefore reserves the right to alter information in this brochure.
Copyright JFC 2011 RRPL Aug. 2011 Rev.001